



FUJI TECHNOLOGY

A BRAND OF 20 YEARS
High-end elevator part in
ELEVATOR INDUSTRY

FUJI TECHNOLOGY CO.,LTD

24-3, Minamihanadacho, Kita-ku Sakai-shi, Osaka, 591-8011, Japan

Tel: +81(0) 723 55 12 03

Email: contact@ml.fujitech.co.jp

Website: fuji.technology



Fuji Technology is a renowned company providing its quality products from Japan to Singapore, Southeast Asia, the Middle East, North, Central, South America, and Africa.

Fuji Technology has its production base located in Japan. We've been recognized by legitimate authorities around the world and have passed various certifications, including European standard, CE, and relevant Japanese standards. To ensure the best quality, we also adopt AMADA machine tools from Japan for manufacturing. Through international marketing strategies, we've successfully achieved the goal of having our elevators seen by people around the world.

Quality Management

Each elevator, traction machine, control panel or accessory is under strict quality controls. We achieve a number of the international standards and received the European CE certification (elevator machine) in 2009. We are dedicated to R&D, obtaining patents both foreign and domestic.

Customization

There are more than a dozen experienced interior designers making our product match your needs. We have a wide range of products from home lifts, hospital elevators, shopping mall escalators to airport moving walk.

Safety

There are more than two hundred accidents related to elevator worldwide annually. Therefore, safety is our first priority.



Fuji Technology Co., Ltd., has set up magnet production line, brake production line, stator core, casting production line and three assembly lines for traction machine. By setting up separate production line, re-arranging working process and improving tools, working efficiency is improved considerably, time-consumption for unit products has been reduced and so has the cost. The realization of balanced production line makes Fuji Technology Co., Ltd the largest PM gearless traction machine and control panel supplier in Japan.



● DRAWING STRENGTH FROM OTHERS, LEAD THE TRENDS IN FUTURE

Scientific and technological innovation is the core power that drives forward the development of an enterprise. Fuji Technology Co., Ltd., places high emphasis on the technological improvement and many other key scientific and technological research institutes in order to make respective advantages complementary to each other. And it also has set up Post-Doctoral Station and Academician Station. Up till now, we have won 128 patents (23 inventions, 71 utility models, 28 industrial design, 6 software copyright). And we have achieved ISO9001 Quality System certification and ISO10012-1 Measurement System Certification. Besides we have been appointed by National Development and Reform Commission and the Ministry of Finance as the company to promote the High-Efficient Motor, the High-Efficient PM Motor sold by Fuji Technology Co., Ltd., accounts for 22.6% shares of the total sales in Japan. All these have established our company as a leading role in the industry in the world.

● THE LAUNCH OF THE GEARLESS TRACTION MACHINE, BRINGS A NEW ERA OF ELEVATOR

From 1999 to 2001 through long-term cooperation and frequent exchanges, the company gradually achieved mature technology and worked together to develop a gearless traction machine having proprietary intellectual property rights. Up till now, the research and development of this technology is still representing the trend of future development of the elevator industry. Machines using this technology do not need excitation and have small starting currents but extremely high transmission efficiency and more reasonable structures.

Compared with traditional traction machines, they have higher efficiency, lower noise, and better environmental and energy. Particularly, after the transmission mechanism is removed, the structure of the machine is lighter, smaller, and more compact. It can be directly installed in the shaft to minimize the building area and cost.





● FUJI PRODUCT

FUJI Passenger Elevator

FUJI VVVF drive ensures FUJI Passenger Elevator operate more smoothly. Nice noise control brings passenger peaceful riding experience. The start, acceleration, brake curves are designed according to the ergonomic theory in order to get the finest coziness.



Home Elevator

FUJI intellectual control system accurately measure the location of car during the operation of elevator; The real time calculation of the system can make sure the best running time always.



FUJI Car Lift

FUJI car elevator win consistent excellent reputation by taking advantage of outstanding stable leveling technology, solid and durable lift car space as well as wide and bright lift car design, enjoys great popularity in the market. With economic development

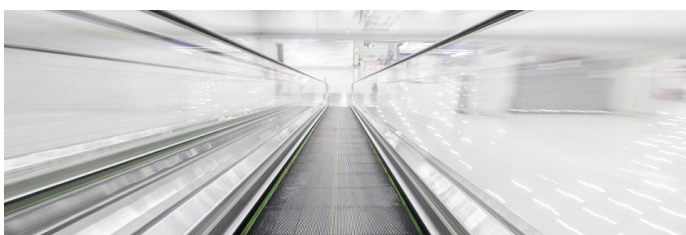

FUJI Escalator

FUJI VVVF drive ensures FUJI Elevator operate more smoothly. Nice noise control brings passenger peaceful riding experience. The start, acceleration, brake curves are designed according to the ergonomic theory in order to get the finest coziness.



FUJI Freight Elevator

FUJI Elevator have gear freight elevator combined with elevator engineering technology and other top technology, strong drive system, high strength of the mechanical structure design, not only can accommodate heavy goods, and can operation



FUJI Moving Walk

The FUJI moving walk brings a new level of simplicity and comfort to shopping. It allows easy and safe access to all parts of the building, even when moving with a loaded cart or trolley.

● FUJI ELEVATOR CONTROLLER

Main Features

- Redundancy control via multi-CPU's equipped with CAN-bus, Modbus, and GSM communication technology.
- Displacement calculation methods derive the N velocity profile to achieve optimum direct-to-point distance control.
- Simple 2-wire serial communications to commission duplex group control.
- Group control of up to 8 elevators is based on fuzzy logic control theory.
- In-built real-time clock to facilitate time-sharing control and elevator management.
- Flexible emergency backup power; 220 VAC power input makes emergency evacuation easy with automatic light load direction search.
- Automatic identification operation between short-floors.
- Handheld operation tools: mini keypad, PC to facilitate easy commissioning.
- 60 fault codes to facilitate easy diagnostics.

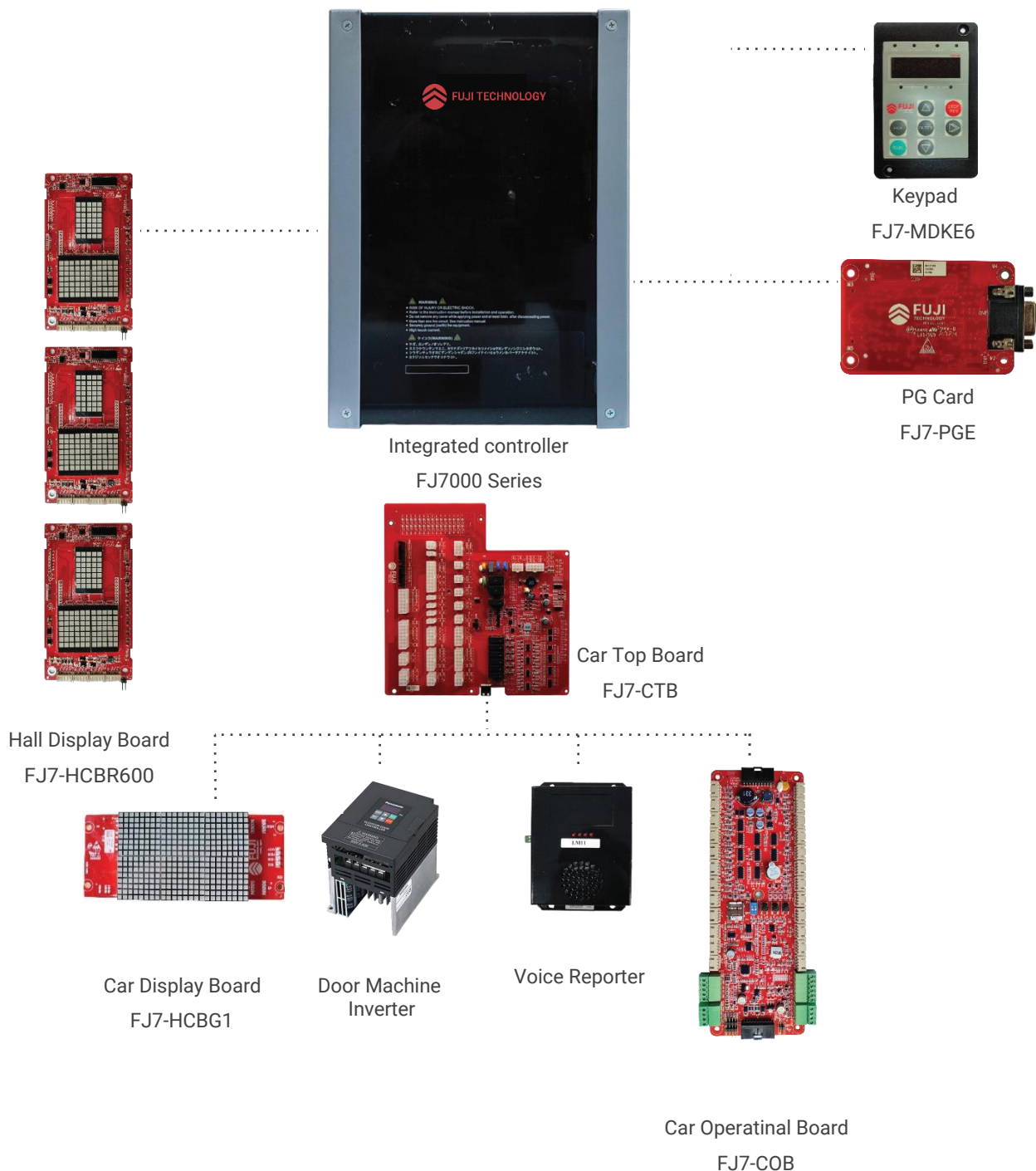



Technical indicators

Power	5.5KW-22KW
Elevator speed	0.4-2.5m/s
Maximum stops	64 stops
Cabinet dimension	1030 * 650 * 300
Controller	FJ7000 series
Wiring connection	Modularized connecting board
Voltage	3P 380V 50Hz 5.5KW-22KW
Adaptive brake specification	DC110V, ≤ 3A
Control method	Single/ Duplex/ Group control
UPS function	Built in
Traction Machine	Gearless permanent magnet synchronous traction machine
Environmental temperature	-10 ÷ 45°C
Installation	Inside the wall/On floor



Model FJ7000	Rated capacity (kVA)	Rated input current (A)	Rated output current (A)	Capacity (kw)
FJ7000-5.5A-4A	8.5	18	13	5.5
FJ7000-7.5A-4A	14	23	18	7.5
FJ7000-11A-4A	18	42	27	11
FJ7000-15A-4A	24	39	34	15
FJ7000-18.5A-4A	29	46	41	18.5
FJ7000-22A-4A	34	53	48	22

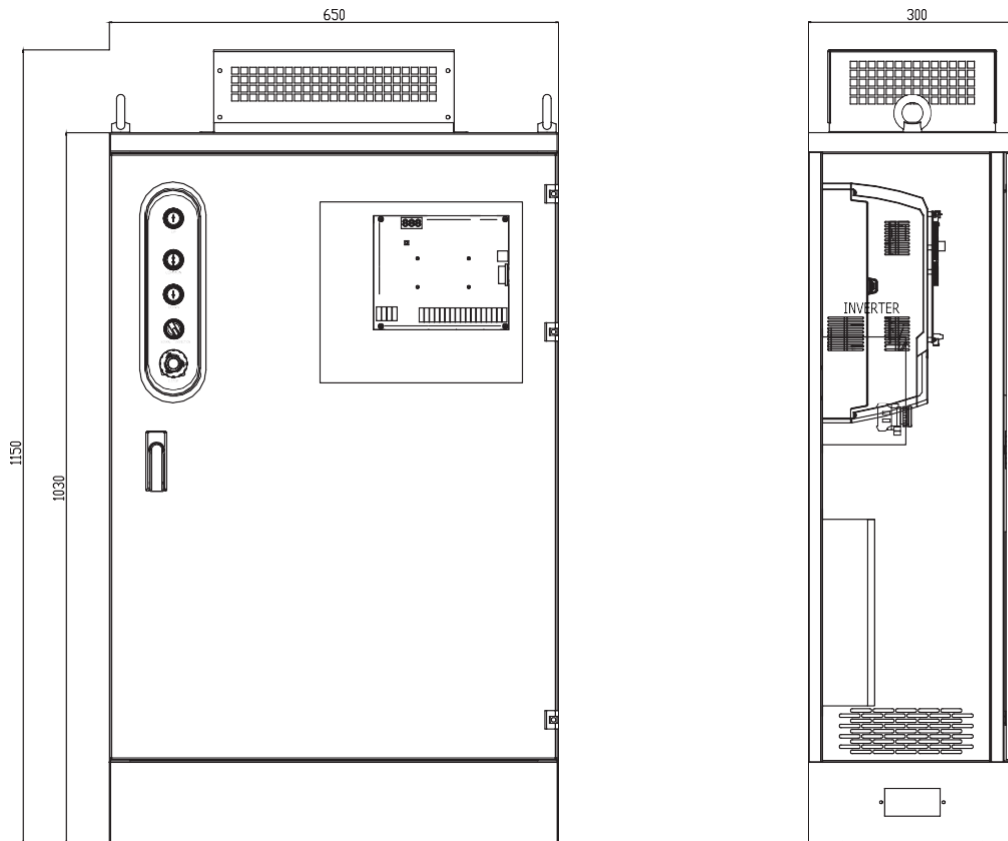

● FUJI ELEVATOR CONTROLLER FOR HOMELIFT

The FJ7000HL honor series is an integrated home elevator control cabinet with innovative, modular and super-compact design by Fuji-technology. Fuji-technology is a brand name for elevator- and escalator-related products exclusively owned by Fuji-technology. Compared to conventional control cabinets in the market, the FJ7000HL has the following major features:

Delicate and compact design

Ultra-thin design, two usage (split type and integrated type), more suitable for installation in the shaft and on the shaft wall, and more convenient for hiding the control cabinet.

Quiet running

Contactor-free technology certified by TUV reduces the noise level during running (< 45 dB), making the running control more quiet.

Comfortable riding

Excellent home elevator drive technology, optimizing riding comfort during elevator running in up/down direction.

Reliable safety

- The safety level reaches SIL3 and multiple anti-trap functions are provided, making the elevator more reliable.
- This guide describes the correct use of the FJ7000HL, including product features, safety instructions, mechanical and electrical installation, commissioning, and maintenance.
- Read this guide carefully before use, and keep it carefully for reference to future maintenance.

Technical indicators

Power	3.7KW/5.5KW
Elevator speed	1.0m/s
Maximum stops	8 stops
Cabinet dimension	1100 * 200 * 100
Controller	FJ7000HL series
Wiring connection	Modularized connecting board
Voltage	3P 380V 50Hz/ 1P 220V 50Hz
Adaptive brake specification	DC110V, ≤ 2.4A
Control method	Single/ Duplex/ Group control
UPS function	Built in
Traction Machine	Gearless permanent magnet synchronous traction machine
Environmental temperature	-20 ÷ 60°C
Installation	Inside the wall

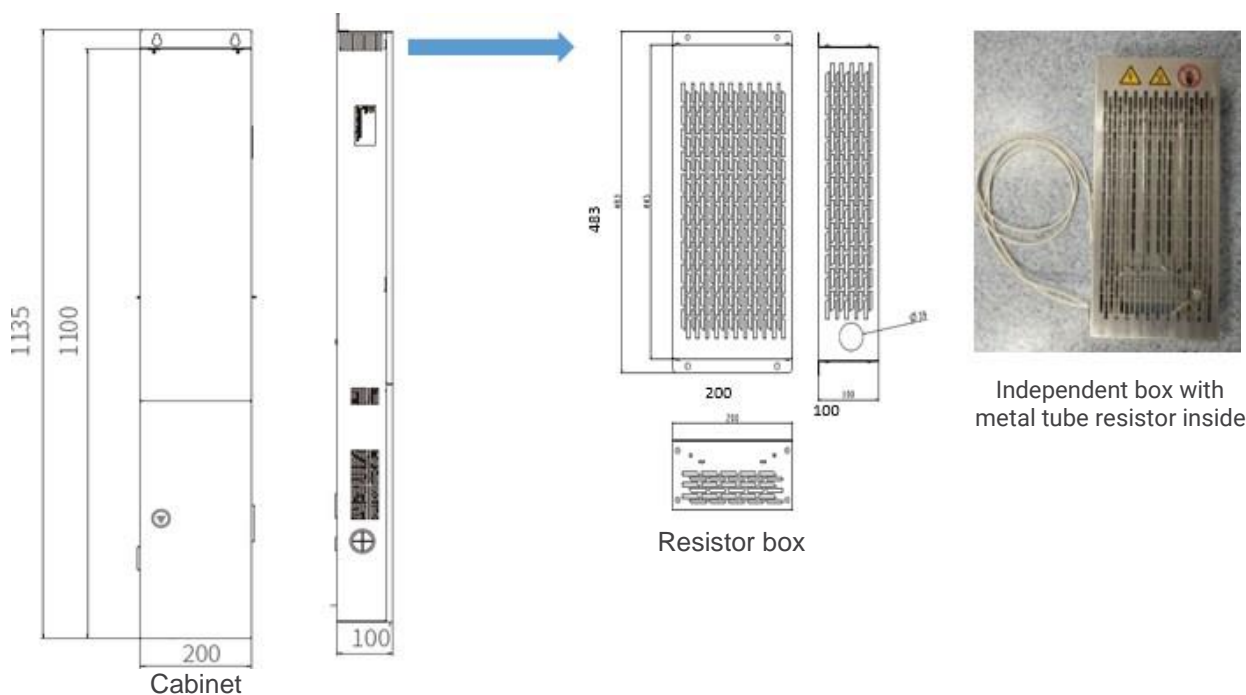

Cabinet model	Rated voltage	Rated power	Rated current
FJ7000HL-3.7A-7A	1P220V	3.7kw	16A
FJ7000HL-5.5A-4A	AC380V	5.5kw	13A

- Brake power supply: DC110V 2.4A.
- Governor coil: AC220V.
- Motor type: synchronous motor (Sin/Cos type encoder).
- Braking resistor:
 - AC380V cabinet(1200W 100Ω).
 - AC220V cabinet(1100W 39Ω).

● FJG7 SERIES MACHINE

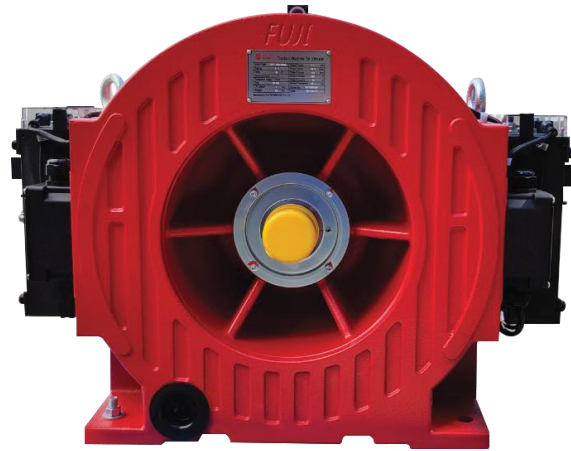

FJG7 Series is Fuji Tech's standard outer rotor type PM gearless traction machine. It is very cost-effective, and is a classic model with largest sale & ownership volume.

Overall Dimensions

Load 500 - 1600kg

Remarks:

1. Both hand wind and hand wind-less types are available.
2. The data in the bracket is for size of hand wind-less type.
3. Use encoder HEIDENHAIN ERN1387 combine with 10m cables.

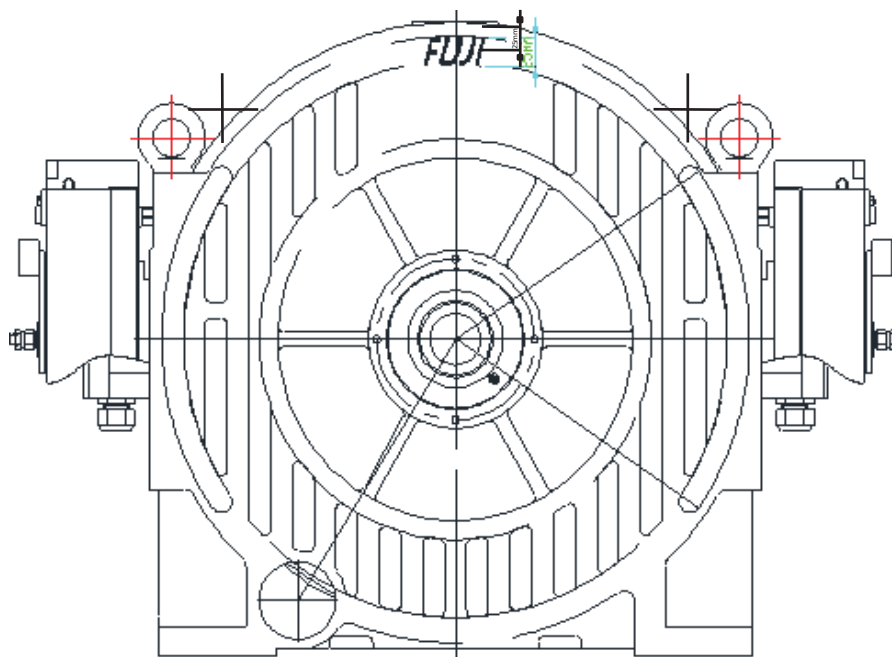

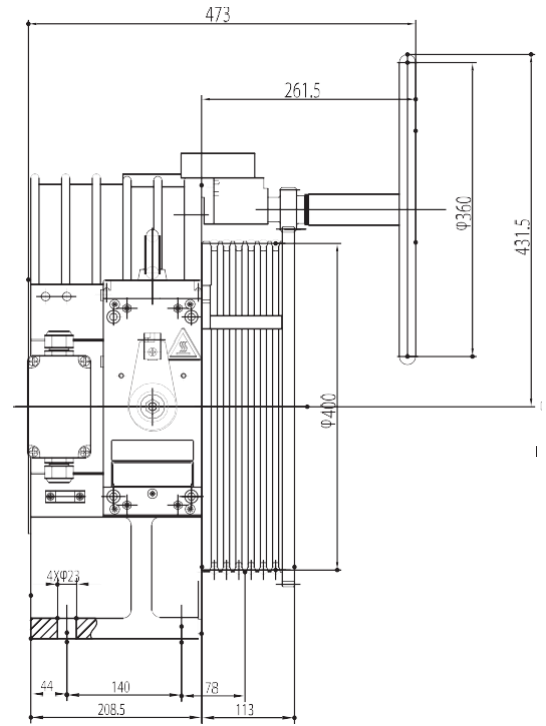
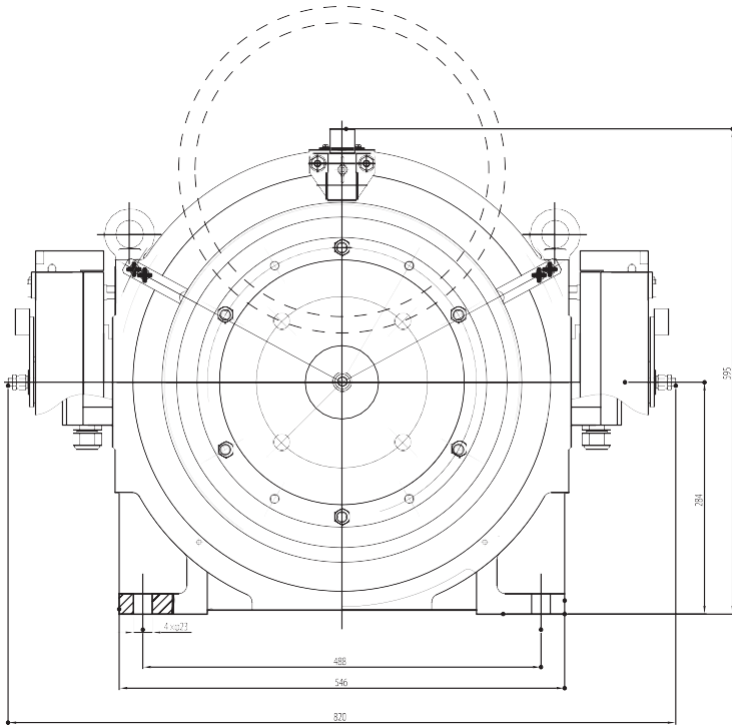
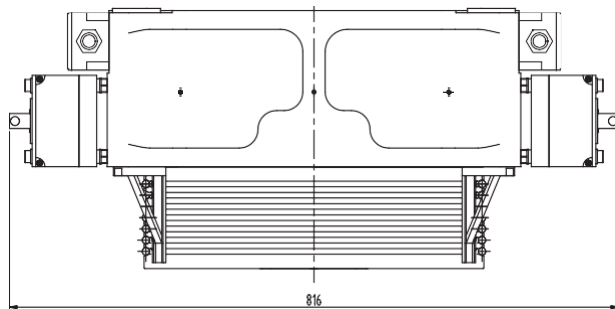
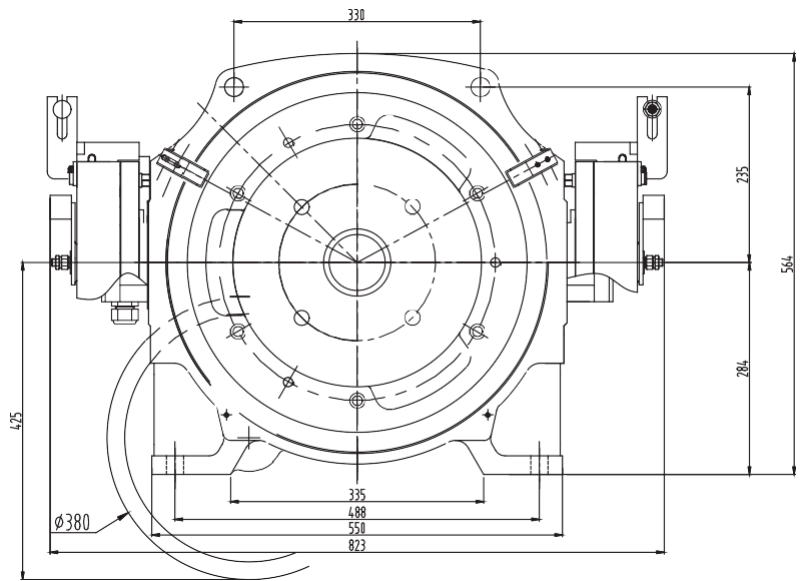
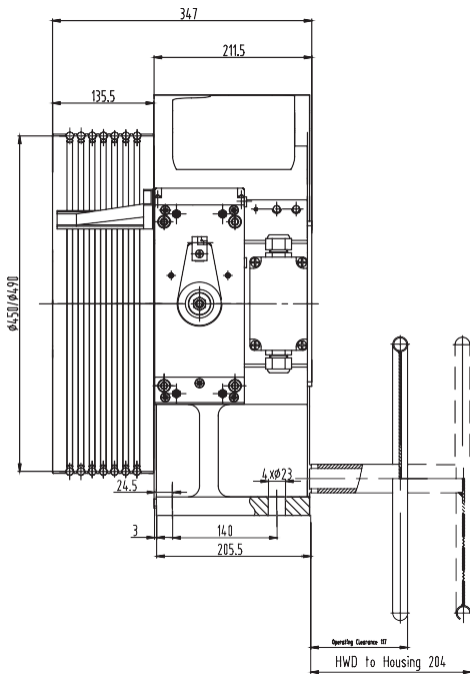
Load 500 - 1000kg

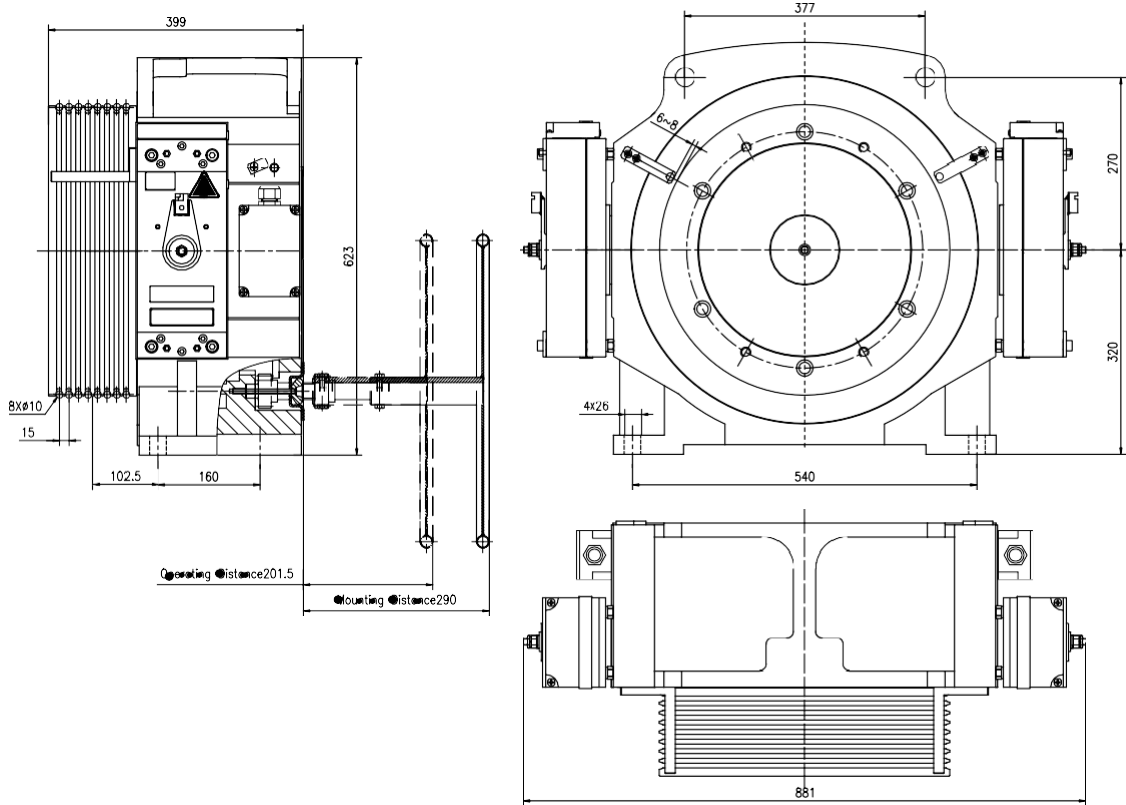
Load 1150kg

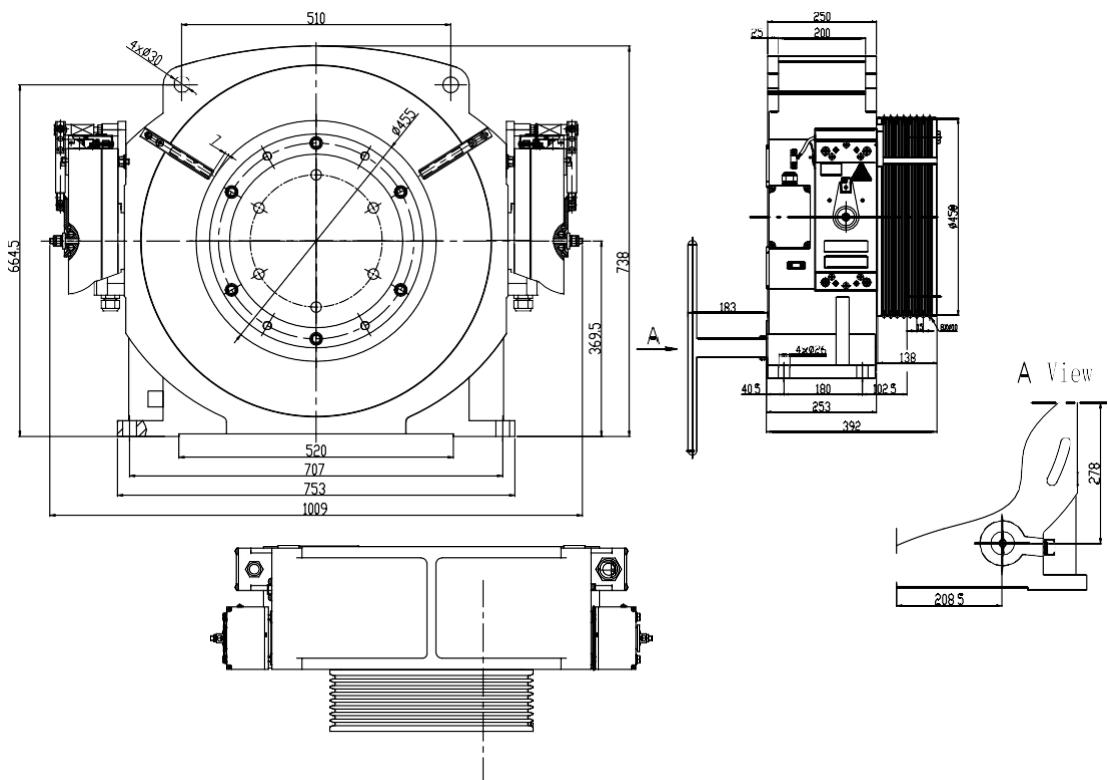

Load 1350kg



Load 1600kg



Specification table

Product type	Traction ratio	Load (Kg)	Static Load (Kg)	Elevator speed (m/s)	Rated speed (r/min)	Rated torque (Nm)	Weight (kg)	Motor					Brake			Sheave		
								Power (Kw)	Voltage (V)	Current (A)	Poles (P)	Frequency (Hz)	Current (A)	Voltage (V)	Brake torque (Nm)	Dimension (mm)	Rope (nxd)	Groove pitche (mm)
FJG7-100/0500	2:1	500	3000	1	95.5	294	354	3.3	340	7.3	32	25.4	2x1.15	DC110	2x515	400	4x8	12
FJG7-150/0500				1.5	143	294		4.5		10.2		38.2						12
FJG7-100/0630	2:1	630	3000	1	95.5	412	352	4.1	340	10	32	25.4	2x1.15	DC110	2x515	400	4x10	15
FJG7-150/0630				1.5	143	412		6.2		14		38.2						15
FJG7-175/0630				1.75	167	412		7.2		16.5		44.5						15
FJG7-100/0800	2:1	800	3000	1	95.5	521	352	5	340	11.5	32	25.4	2x1.15	DC110	2x668	400	5x10	15
FJG7-150/0800				1.5	143	521		7.8		17		38.2						15
FJG7-175/0800				1.75	167	521		9		21		44.5						15
FJG7-200/800	2:1	800	3500	2.0	170	551	385	9.8	340	20.6	32	45.3	2x1.1	DC110	2x880	450	7x10	15
FJG7-100/1000	2:1	1000	3000	1	95.5	669	352	6	340	14	32	25.4	2x1.15	DC110	2x668	400	6x10	15
FJG7-150/1000				1.5	143	669		10		22.3		38.2						15
FJG7-175/1000				1.75	167	669		11.7		26		44.5						15
FJG7-100/1150	2:1	1150	3500	1	85	793	471	7	340	17.3	32	22.7	2x1.15	DC110	2x940	450	7x10	15
FJG7-150/1150				1.5	127	793		10.6		22.7		33.9						15
FJG7-175/1150				1.75	149	793		12.3		28		39.6						15
FJG7-200/1150	2:1	1150	3500	2.0	170	793	471	14.1	340	34.5	32	33.9	2x1.1	DC110	2x880	450	8x10	15
FJG7-100/1350	2:1	1350	5000	1.0	85	1015	565	9.0	340	20.5	32	22.6	2x1.15	DC110	2x1270	450	8x10	15
FJG7-150/1350				1.5	127	1015		13.5		30		34.0						15
FJG7-175/1350				1.75	149	1015		15.8		35		39.6						15
FJG7-100/1600	2:1	1600	6000	1.0	85	1176	652	10.5	340	23	32	22.7	2x1.15	DC110	2x1470	450	8x10	15
FJG7-150/1600				1.5	127	1176		15.7		34.5		33.9						15
FJG7-175/1600				1.75	149	1176		18.3		39		39.7						15
FJG7-100/2500	2:1	2500	8000	1.0	74	2172	1010	16.7	340	35	32	19.6	2x1.8	DC110	2x3188	520	7x13	20
FJG7-150/2500	2:1	2500	8000	1.5	110	2172	1010	25.0	340	56	32	29.3	2x1.8	DC110	2x3188	520	7x13	20
FJG7-175/2500	2:1	2500	8000	1.75	129	2172	1010	29.2	340	66	32	34.3	2x1.8	DC110	2x3188	520	7x13	20
FJG7-100/2000	2:1	2000	6000	1	85	1470	682	13.1	340	29.5	32	22.7	2x1.15	DC110	2x1838	450	9x10	15
FJG7-175/2000	2:1	2000	6000	1.75	149	1470	682	22.9	340	48.5	32	39.7	2x1.15	DC110	2x1838	450	9x10	15
FJG7-100/3000	2:1	3000	8000	1.0	73.5	2550	1010	19.6	340	43	32	19.6	2x2.7	DC110	2x3188	520	7x13	20

● BELT MACHINE SERIES

FJG7-F Home Elevator Version

Due to increase needs of home (belt villa) elevator, Fuji-Technology group develop FJ7G-F series belt drive PMS machine. The belt machine can work with Fuji belt (STD 43) to achieve best lift comfort level with minimum operation noise. This series machine has small size suitable for MRL design and easy maintenance.

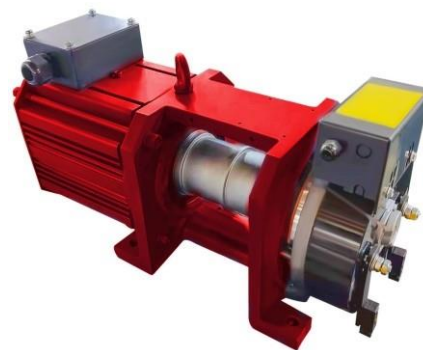

Parameter of Traction Machine

Voltage: AC380V
 Roping: 2 : 1
 Wrap: Single
 Capacity: 450kg
 Wheel Diameter: $\Phi 100$
 Speed: 0.4m/s ~ 1.0m/s
 Protection Grade: IP41
 Ins. Class: F
 Traction machine pole: 20
 Stars per hour: 150
 Rating : S5-25%

Features

- ⊖ Machine is made of aluminum alloy material, with good heat dissipation, small size and light weight;
- ⊖ Configured with shaft brake of low noise and compact structure;
- ⊖ Adopt two blance full sealed bears, free maintain;
- ⊖ Smooth running, excellent performance at low speed.

Overall Dimension

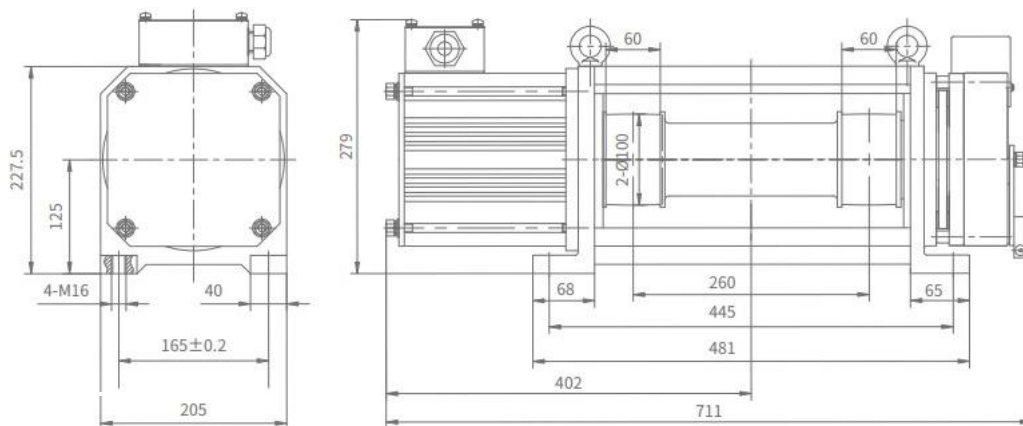

Specification table

Product type	Traction ratio	Load (Kg)	Static Load (Kg)	Elevator speed (m/s)	Rated speed (r/min)	Rated torque (Nm)	Weight (kg)	Motor					Brake			Sheave			
								Power (Kw)	Voltage (V)	Current (A)	Poles (P)	Frequency (Hz)	Current (A)	Voltage (V)	Brake torque (Nm)	Dimension (mm)	Num	Width (mm)	Pitch (mm)
FJG7-K 040/0450	2:1	450	2000	0.4	153	70	100	1.1	380	3.3	20	25.5	2x1.5	DC110	2x515	100	2	60	260
FJG7-K 100/0450				1.0	382	70		2.8		6.4		63.7							

• BELT MACHINE SERIES
FJG7-K Commercial Elevator Version

Due to increase needs of belt elevator, Fuji-Technology group develop FJ7G-K series belt drive PMS machine. The belt machine can work with Fuji belt (STD 43) to achieve best lift comfort level with minimum operation noise. This series machine has small size suitable for MRL design and easy maintenance.

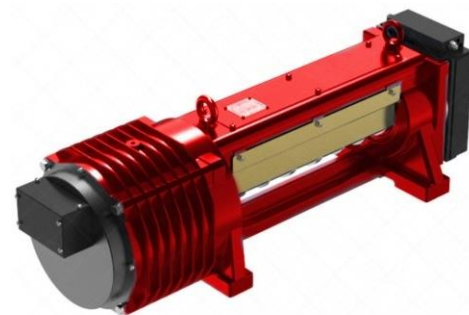

Parameter of Traction Machine

Voltage: AC380V
 Roping: 2 : 1
 Wrap: Single
 Capacity: 630kg-2000kg
 Wheel Diameter: $\Phi 100$
 Speed: 1.0m/s ~ 2.0m/s
 Protection Grade: IP41
 Ins. Class: F
 Traction machine pole: 20
 Stars per hour: 240
 Rating : S5-40%

Features

- ⊖ Double support structure, reliable structure, better performance;
- ⊖ Configured with shaft brake of low noise and compact structure;
- ⊖ Use self-sealed bearings, maintenance-free;
- ⊖ Electromagnetic structure optimization, smooth running and low noise

Overall Dimension

Load 630kg

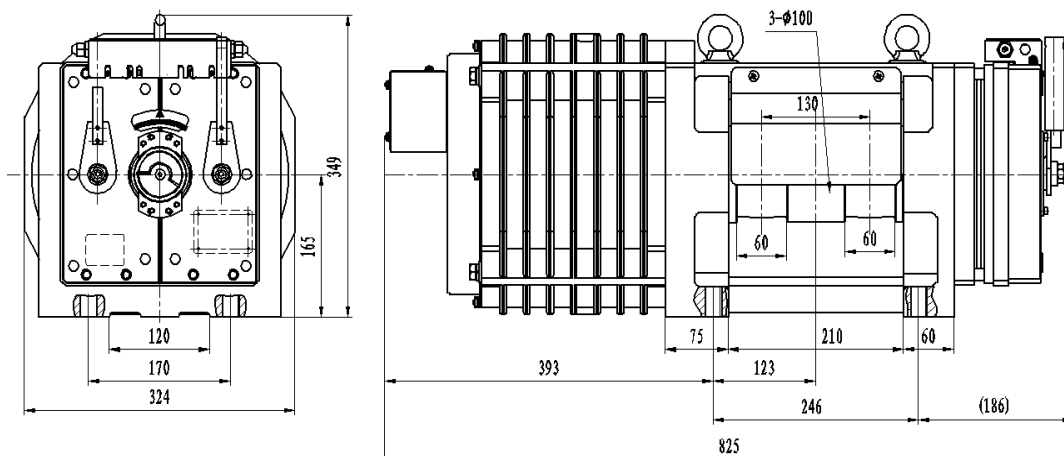

Load 630 - 1150kg

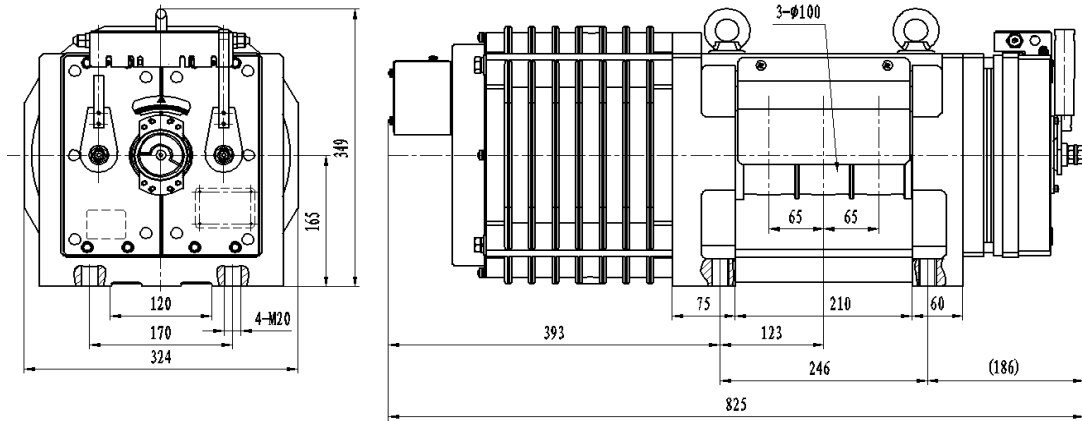

Load 1275 - 1350kg

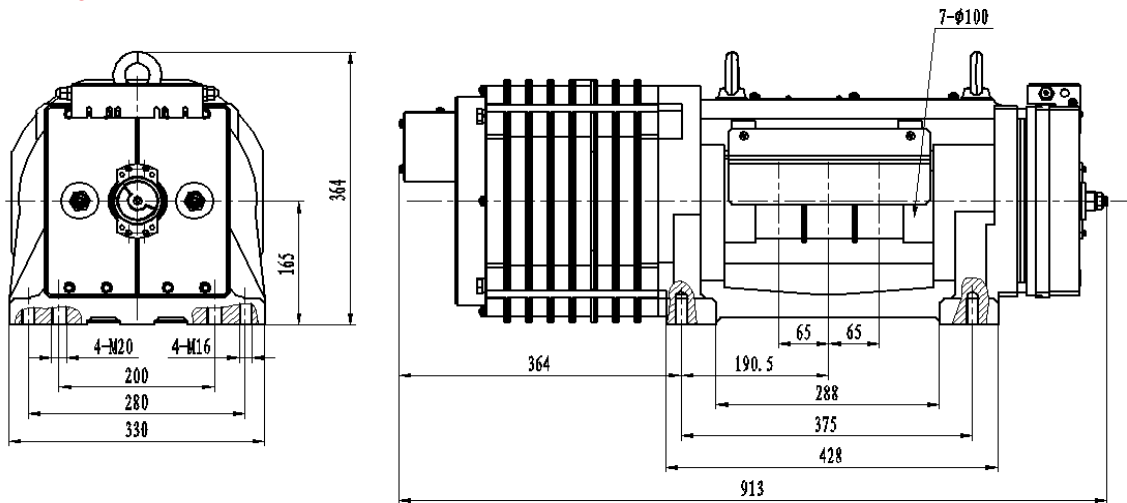

Load 1600 - 2000kg

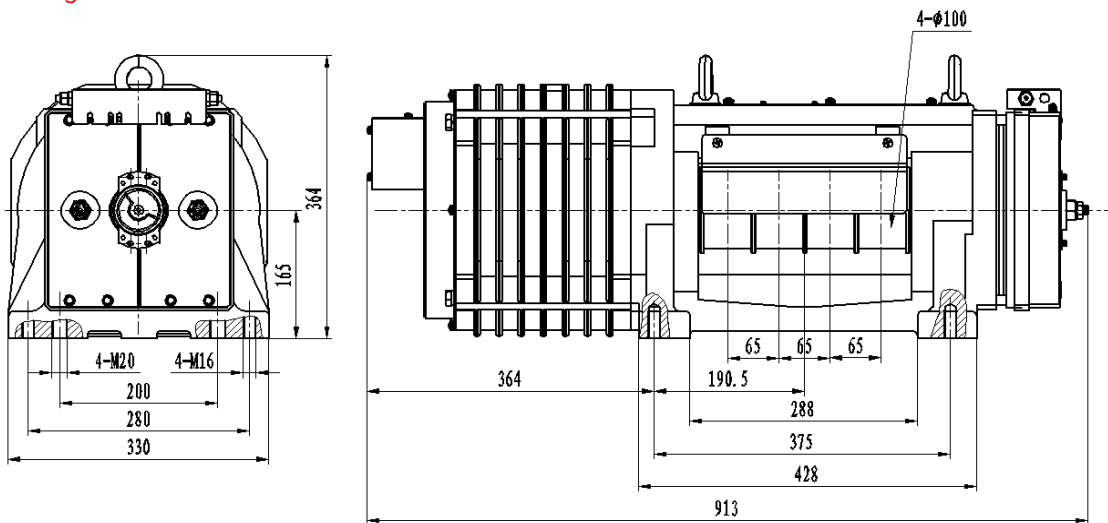



Specification table

Product type	Traction ratio	Load (Kg)	Static Load (Kg)	Elevator speed (m/s)	Rated speed (r/min)	Rated torque (Nm)	Weight (kg)	Motor					Brake		Sheave			
								Power (Kw)	Voltage (V)	Current (A)	Poles (P)	Frequency (Hz)	Current (A)	Voltage (V)	Dimension (mm)	Num	Width (mm)	Pitch (mm)
FJG7-K 100/0630/2		630	3000	1.0	382	105	≈260	4.2	380	9.9	20	63.7	2x0.69	DC110	100	2	60	65
FJG7-K 150/0630/2				1.5	573			6.3		16.8		95.5						
FJG7-K 160/0630/2				1.6	611			6.7		17		101.9						
FJG7-K 175/0630/2				1.75	668			7.3		17.2		111.4						
FJG7-K 200/0630/2				2.0	764			8.4		19.5		127.3						
FJG7-K 100/0630/3		630		1.0	382	4.2		9.9		63.7		100			3	60	65	
FJG7-K 150/0630/3				1.5	573	6.3		16.8		95.5								
FJG7-K 160/0630/3				1.6	611	6.7		17		101.9								
FJG7-K 175/0630/3				1.75	668	7.3		17.2		111.4								
FJG7-K 200/0630/3				2.0	764	8.4		19.5		127.3								
FJG7-K 100/0800/3		800		1.0	382	5.2		12.4		63.7		100			3	60	65	
FJG7-K 150/0800/3				1.5	573	7.8		20.8		95.5								
FJG7-K 160/0800/3				1.6	611	8.3		21		101.9								
FJG7-K 175/0800/3				1.75	668	9.1		21.2		111.4								
FJG7-K 200/0800/3				2.0	764	10.4		24		127.3								
FJG7-K 100/1000/3		1000	1.0	382	6.8	15.6	63.7	100	3	60	65							
FJG7-K 150/1000/3			1.5	573	10.2	26.7	95.5											
FJG7-K 160/1000/3			1.6	611	10.9	26.8	101.9											
FJG7-K 175/1000/3			1.75	668	11.9	27	111.4											
FJG7-K 200/1000/3			2.0	764	13.6	30.8	127.3											
FJG7-K 100/1150/3		1150	1.0	382	7.6	17.5	63.7	100	3	60	65							
FJG7-K 150/1150/3			1.5	573	11.4	29.8	95.5											
FJG7-K 160/1150/3			1.6	611	12.2	30	101.9											
FJG7-K 175/1150/3			1.75	668	13.3	30.3	111.4											
FJG7-K 200/1150/3			2.0	764	15.2	34.4	127.3											
FJG7-K 100/1275/3		1275	1.0	382	8.4	19	63.7	100	3	60	65							
FJG7-K 150/1275/3			1.5	573	12.6	32.6	95.5											
FJG7-K 160/1275/3			1.6	611	13.4	32.8	101.9											
FJG7-K 175/1275/3			1.75	668	14.7	33	111.4											
FJG7-K 200/1275/3			2.0	764	16.8	37.7	127.3											
FJG7-K 100/1275/7		1275	1.0	382	8.4	19	63.7	100	7	60	65							
FJG7-K 150/1275/7			1.5	573	12.6	32.6	95.5											
FJG7-K 160/1275/7			1.6	611	13.4	32.8	101.9											
FJG7-K 175/1275/7			1.75	668	14.7	33	111.4											
FJG7-K 200/1275/7			2.0	764	16.8	37.7	127.3											

Specification table

Product type	Traction ratio	Load (Kg)	Static Load (Kg)	Elevator speed (m/s)	Rated speed (r/min)	Rated torque (Nm)	Weight (kg)	Motor					Brake		Sheave			
								Power (Kw)	Voltage (V)	Current (A)	Poles (P)	Frequency (Hz)	Current (A)	Voltage (V)	Dimension (mm)	Num	Width (mm)	Pitch (mm)
FJG7-K 100/1350/3		1350	5000	1.0	382	220	≈360	8.8	380	20	20	63.7	2x1.5	DC110	100	3	60	65
FJG7-K 150/1350/3				1.5	573			13.2		34.4		95.5						
FJG7-K 160/1350/3				1.6	611			14.1		34.6		101.9						
FJG7-K 175/1350/3				1.75	668			15.4		34.8		111.4						
FJG7-K 200/1350/3				2.0	764			17.6		39.7		127.3						
FJG7-K 100/1350/7		1350		1.0	382	220		8.8		20		63.7						
FJG7-K 150/1350/7				1.5	573	13.2		34.4		95.5								
FJG7-K 160/1350/7				1.6	611	14.1		34.6		101.9								
FJG7-K 175/1350/7				1.75	668	15.4		34.8		111.4								
FJG7-K 200/1350/7				2.0	764	17.6		39.7		127.3								
FJG7-K 100/1600/4		1600		1.0	382	265		10.6		24		63.7						
FJG7-K 150/1600/4				1.5	573			15.9		41.4		95.5						
FJG7-K 160/1600/4				1.6	611			17.0		41.6		101.9						
FJG7-K 175/1600/4				1.75	668			18.5		41.8		111.4						
FJG7-K 200/1600/4				2.0	764			21.2		47.8		127.3						
FJG7-K 100/1600/7		1600	1.0	382	265	10.6	24	63.7										
FJG7-K 150/1600/7			1.5	573		15.9	41.4	95.5										
FJG7-K 160/1600/7			1.6	611		17.0	41.6	101.9										
FJG7-K 175/1600/7			1.75	668		18.5	41.8	111.4										
FJG7-K 200/1600/7			2.0	764		21.2	47.8	127.3										
FJG7-K 100/2000/4		2000	1.0	382	340	13.6	30	63.7										
FJG7-K 150/2000/4			1.5	573		20.4	50.2	95.5										
FJG7-K 160/2000/4			1.6	611		21.8	50.4	101.9										
FJG7-K 175/2000/4			1.75	668		23.8	50.6	111.4										
FJG7-K 200/2000/4			2.0	764		27.2	57.7	127.3										
FJG7-K 100/2000/7		2000	1.0	382	340	13.6	30	63.7										
FJG7-K 150/2000/7			1.5	573		20.4	50.2	95.5										
FJG7-K 160/2000/7			1.6	611		21.8	50.4	101.9										
FJG7-K 175/2000/7			1.75	668		23.8	50.6	111.4										
FJG7-K 200/2000/7			2.0	764		27.2	57.7	127.3										

● **HOSTING BELT**
32KN Hosting Belt for Elevator

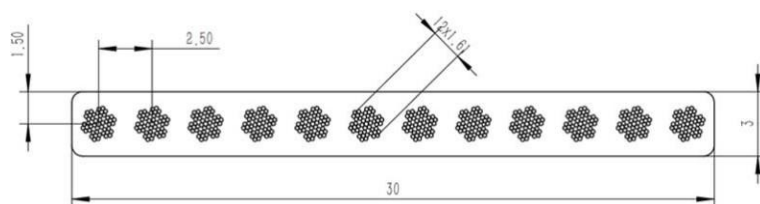

Parameter of Belt

Item	Unit	Target	Max.	Min.	Remarks
Thickness	mm	3	3.1	2.9	
Width	mm	30	31	29.5	
Breaking Force	KN	36	-	32	
Elongation at Break	%	-	2	-	
Low Load Elongation	%	1.26	0.35		2%-10% Axil Load
Diam. of Ropes Inside	mm	12	1.67	1.57	
Strength of Single Rope	N	3200	-	2960	
Pullout Force of Rope	N/mm	-	-	30	Embedded Length 30mm
Hardness (HA)		95	98	92	
Equivalent Friction Coefficient		0.45	0.55	0.35	Axil Load 8%
Residual Strength	KN			29	After 10,000,000 Bendings
Strength of Belt Grip	KN			30	
High Temperature Creep	-	0			40 C, 40 hours, grip does not disengage
Room Temperature Creep	%		0.5		Elongation ratio after 120 days in room temperature

● SAFETY GEAR

Double lift type

Technical Parameters

Model	FJSG01
Rated Speed	≤ 2.5 m/s
Tripping Speed	≤ 3.23 m/s
Total mass(P+Q)	750kg - 3200kg
Width of guide rail	10mm



Overall Dimension

Bottom beam mounting interface dimensions(mm)				Guide shoe interface dimensions(mm)			
A	B	C	D1	a	b	c	d1
55	60	80	4xM12	60	70	90	4x ϕ 18

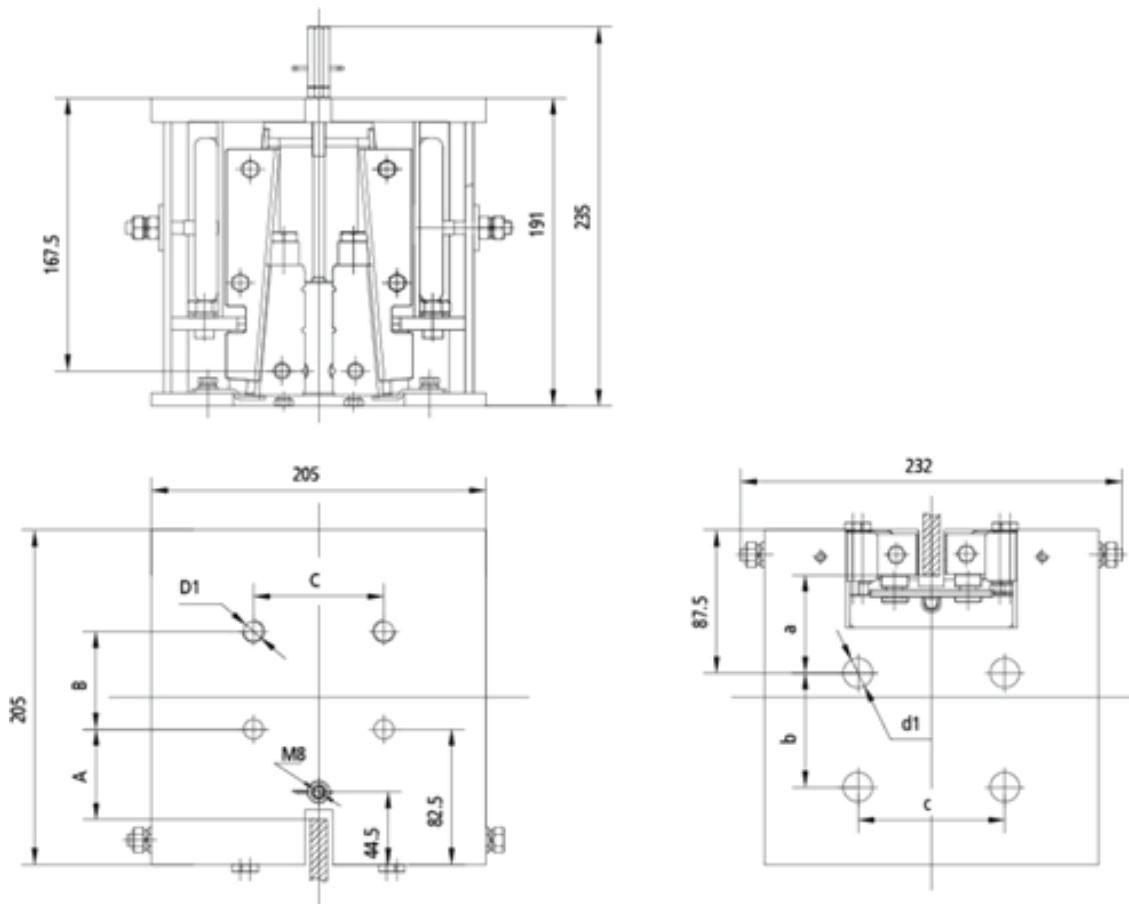

● SAFETY GEAR

Double lift type

Technical Parameters

Model	FJSG02
Rated Speed	≤ 2.5 m/s
Tripping Speed	≤ 3.23 m/s
Total mass(P+Q)	3000kg - 6000kg
Width of guide rail	16mm



Overall Dimension

Bottom beam mounting interface dimensions(mm)				Guide shoe interface dimensions(mm)			
A	B	C	D1	a	b	c	d2
55	60	80	4xM12	60	70	2xø18	2xM16

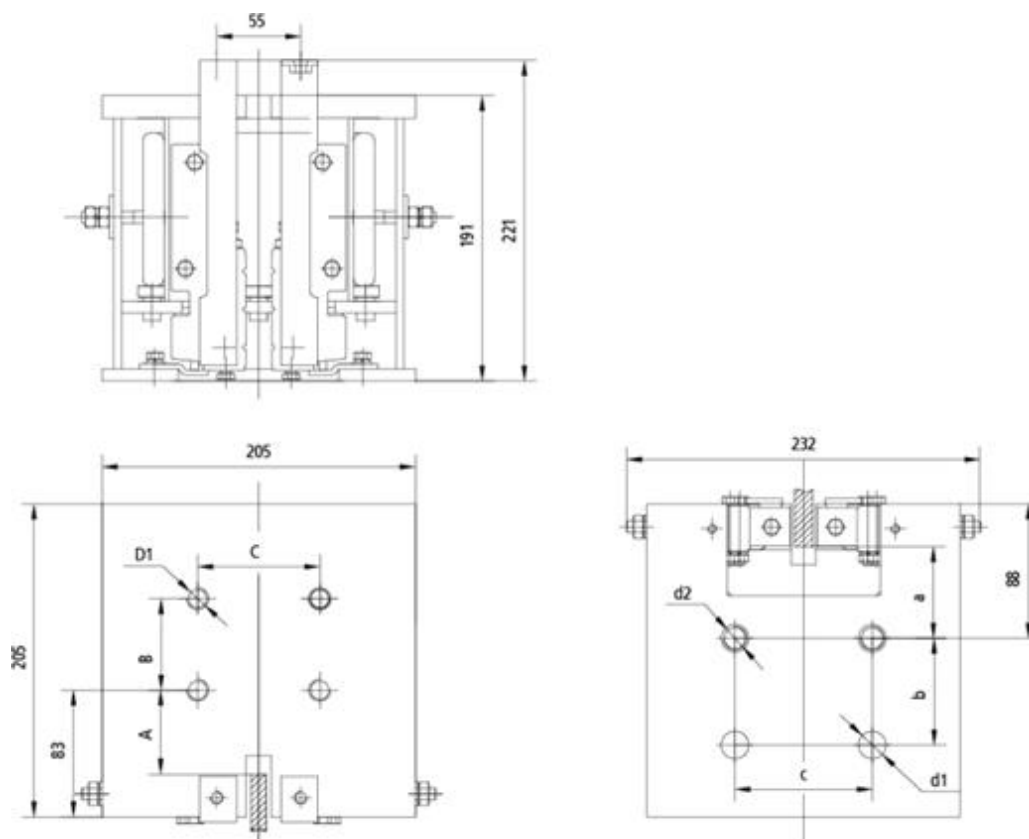

● OVER-SPEED GOVERNOR

Technical Parameters

Product Name	Overs-peed Governor
Product Model	FJG240A
Rated Speed Range	0.5-2.5 m/s
Activation Speed Range	0.58-3.23 m/s
Sheave Diameter	240mm
Rope Tension Force	1000-2000N
Rope Dia	8mm
Car Travel	$0 \leq H \leq 150$



Overall Dimension

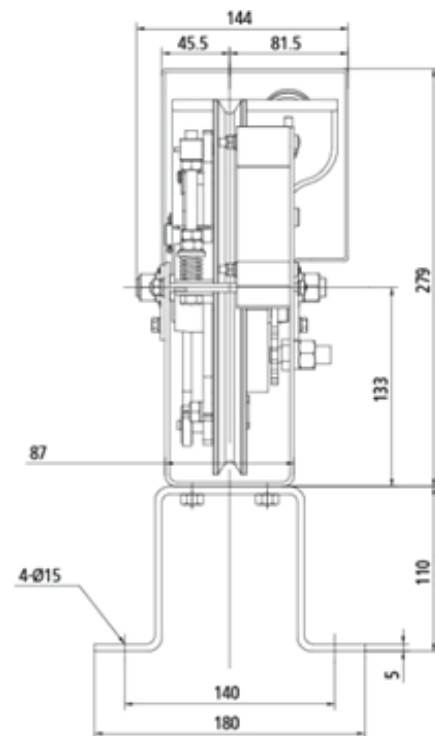
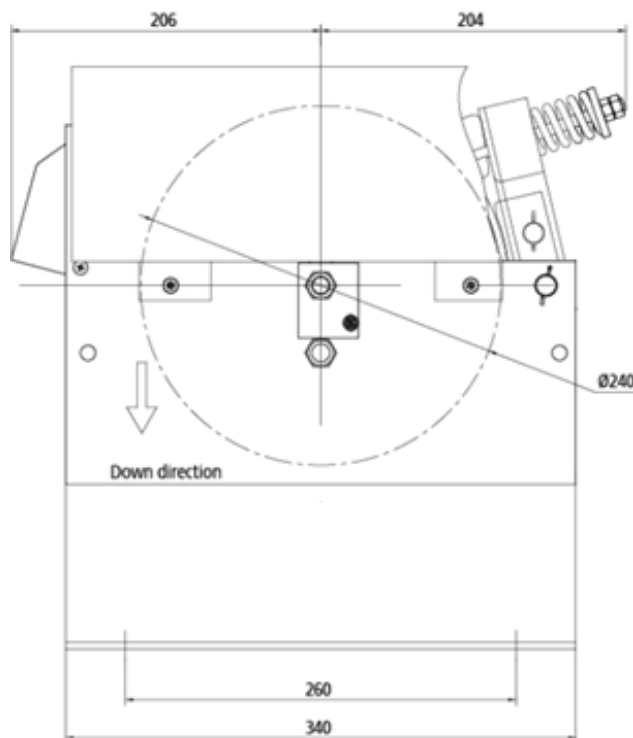



● FJ-TD TENSION DEVICE

Technical Parameters

Product Name	Tension device
Product Model	FJ-TD
Sheave Diameter	240mm
Rope Dia	8mm

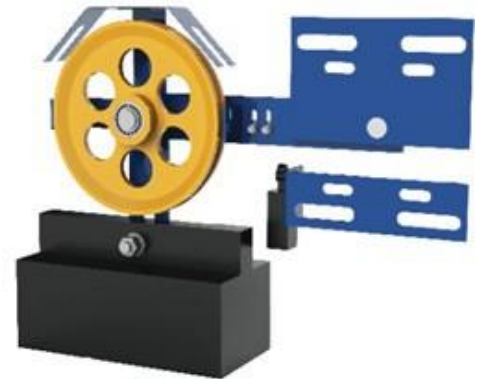

Overall Dimensions

Product model	Quality of balancing	Recommended height	Weight material	A (mm)	B (mm)	D (mm)	E (mm)	F (mm)	G (mm)
FJ-TD180A	18kg	0≤H≤60	Barite	320	29	310	145	175	64
					55.5				
FJ-TD300A	30kg	0≤H≤120	Barite	320	29	310	145	175	74
					55.5				

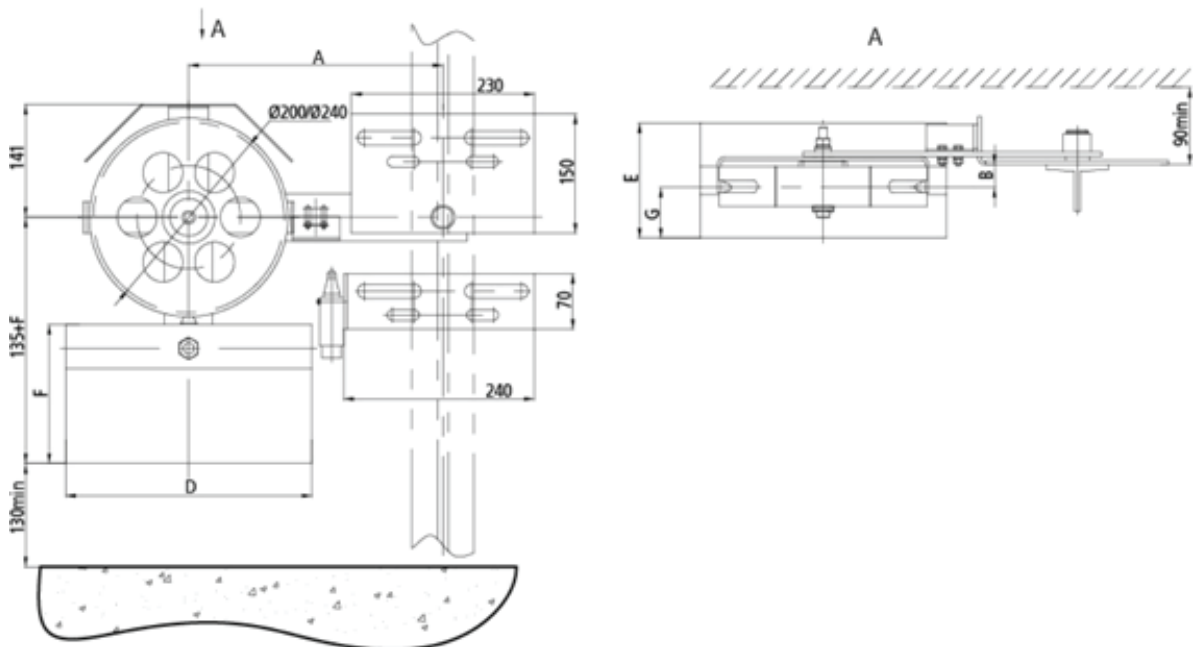

● HYDRAULIC BUFFER

Model FJ-HB80A

Technical Parameters

Product Name	Hydraulic Buffer
Product Model	FJ-HB80A
Rated Speed Range	$\leq 1.0\text{m/s}$
Rated Load Range	600-3000kg

Mounting interface dimensions(mm)				
A	B	C	H	4x ϕ D
279	90	90	80	4x ϕ 14

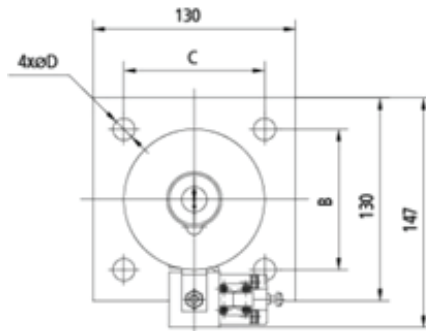
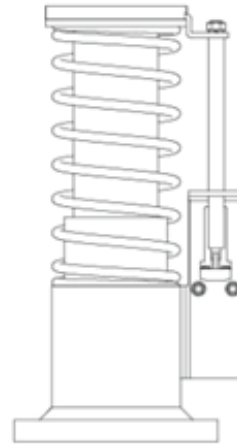
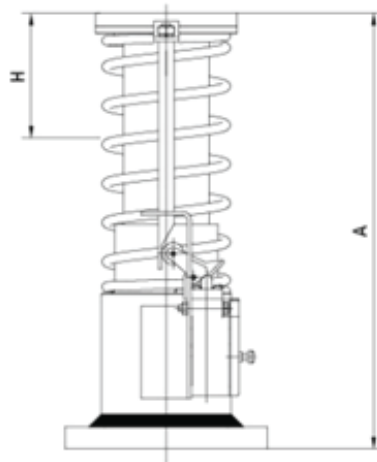



● SAFETY GEAR

Double lift type

Product Name	Hydraulic Buffer
Product Model	FJ-HB175A
Rated Speed Range	≤1.75m/s
Rated Load Range	600-3000kg

Mounting interface dimensions(mm)				
A	B	C	H	4xφD
526	90	90	175	4xφ14

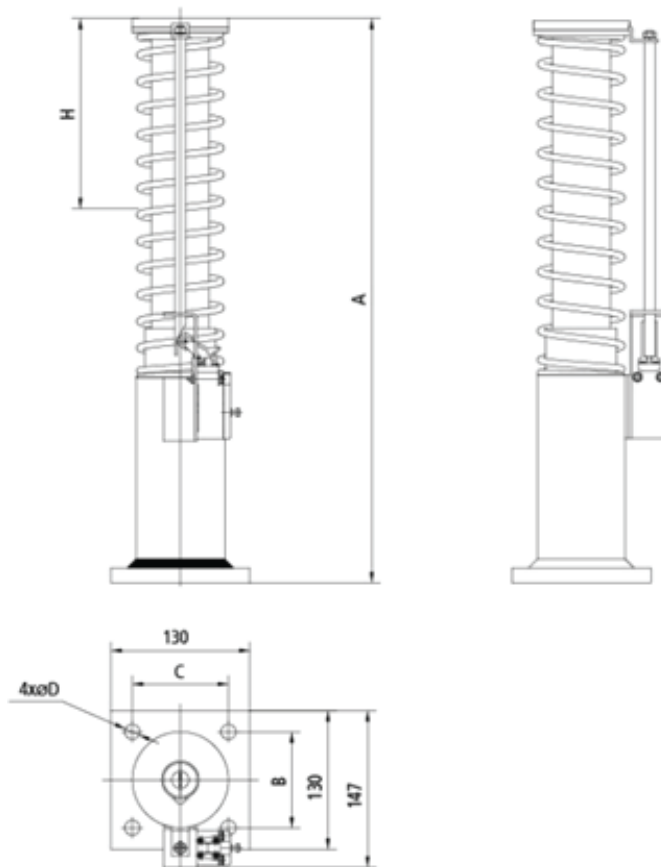



FUJI TECHNOLOGY

24-3, Minamihanadacho, Kita-ku Sakai-shi, Osaka, 591-8011, Japan

Tel: +81(0) 723 55 12 03

Email: contact@ml.fujitech.co.jp

Website: fuji.technology